



The MS-LED-1H-180 is equivalent to a 300 watt quartz unit with a total of 1800 lumens out of the fixture. Whenever the motion sensor detects motion the floodlight automatically turn on. The sensor is adjustable and can turn the light on from 5 seconds to 12 minutes.

### APPLICATIONS

**Ideal for residential security lighting, building perimeters, and building entrances.**

<b>Project</b>	
<b>Type</b>	
<b>Date</b>	
<b>Notes</b>	

### SPECIFICATIONS

#### Construction

The MS-LED-1H-180 has a 180 degree sensor and comes with one LED flood and mounting plate.

#### Photo Electric Control

Deactivates lights during daylight. Fully adjustable for 24 hour operation or custom applications.

#### LED Flood

Extruded aluminum with clear lens. Unit has nine LEDs providing 1800 lumens out of the fixture.

#### Mounting Plate

Cast aluminum.

#### Finish

White or Black

#### Mounting

Fits over a standard octagon box.

<b>Equivalent to</b>	<b>150 PAR Inc</b>
<b>Watts</b>	<b>27W</b>
<b>Lumens</b>	<b>1,800</b>
<b>Efficiency</b>	<b>66.7 lumens/watt</b>

<b>LED Life</b>	<b>100,000 hours</b>
<b>Colour Temperature</b>	<b>4,000K</b>
<b>Warranty</b>	<b>5 Years</b>
<b>Operating Temperature</b>	<b>-30° C to +50° C</b>
<b>Certification</b>	<b>cCSAus</b>

### DIMENSIONS

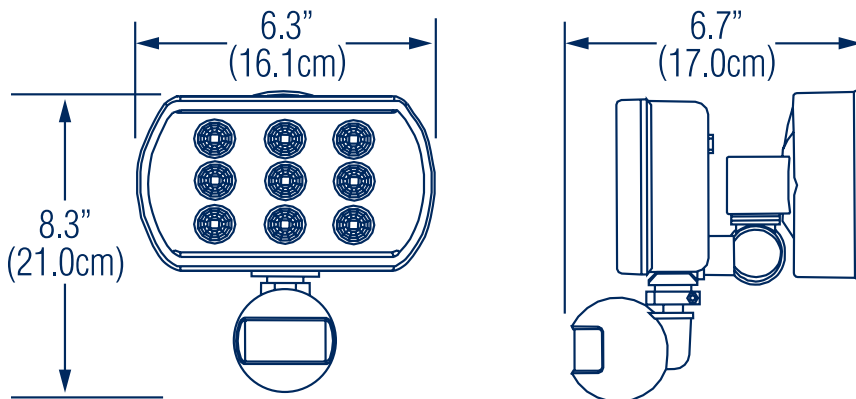

DETECTION RANGE

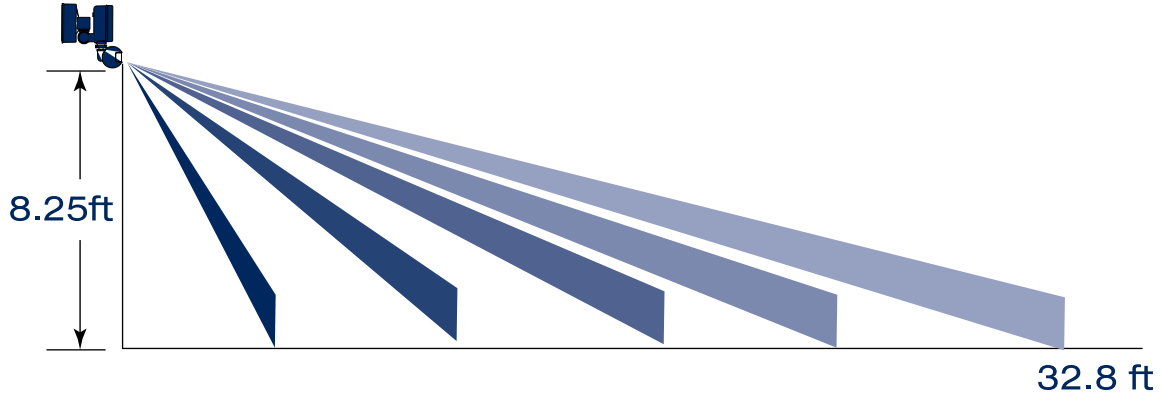

ORDERING GUIDE

<b>MS</b>	-	<b>LED-1H</b>	-		-	
		<b>VOLTAGE</b>	<b>COLOR TEMP</b>		<b>FINISH</b>	
		<b>A - 120V*</b>	<b>4K - 4000K*</b>		<b>BLK - BLACK WHT - WHITE</b>	

\* Standard configuration